

Pile bearing capacity prediction by means of static penetrometer CPT

M. BUSTAMANTE & L. GIANESELLI

Laboratoire Central des Ponts et Chaussées, Paris, France

1 INTRODUCTION

Although there is considerable literature relative to pile bearing capacity prediction and many design methods are proposed, every skilled pile designer knows that making bearing capacity predictions such that they are reasonably close, if only to within 20 % of the real value, is always very difficult. The discrepancies observed between real and theoretical bearing capacities are explained by the fact that present design methods have been developed on the basis of questionable and often insufficient experimental data. Among the essential causes which limit the scope or the representativeness of most existing design methods should be mentioned :

- the small number of piles and placement techniques taken into account in working out the proposed method,
- the inadequacy of instrumentation, not capable of distinguishing the amount of the load taken by skin friction and by the pile point,
- the total unfamiliarity or limited knowledge concerning not only pile geometry but also the equivalent moduli of the constituent material,
- finally, the absence of monitoring for pile construction or placement operations.

Among the methods used for predicting the bearing capacity of vertically loaded isolated piles, the following are distinguished :

- so-called dynamic methods based upon the interpretation of pile driving data and hence limited to the driven piles,
- methods based upon the use of the parameters c and ϕ measured in the laboratory on samples assumed to be undisturbed,
- methods using the results of in-situ investigations, with tests of the dynamic pen-

netrometer type (SET, for example) or the quasi-static type (CPT) but also pressuremeter tests.

The latter two design methods (CPT and pressuremeter), introduced in the 1960s [1] [2] [3] [4], were adopted in 1972 by the FOND 72 document [5] to which reference is still made today in France for all foundation design calculations for highway structures. However, as of 1964, the laboratory network of the French Highway Department (Laboratoires des Ponts et Chaussées) undertook the experimental verification of the validity of these two methods. The experimental data required for the readjustment of the two methods mentioned were furnished by a large number of full-scale loading tests after comparing real and theoretical bearing capacities. This paper deals only with the conclusions and proposals relative to the static penetrometer (CPT) method, as the formulation of new pressuremeter rules has been dealt with in recent articles [6].

2 EXPERIMENTAL DATA AND REMARKS ON THE PENETROMETER TESTS (CPT)

The penetrometer rules proposed by the authors of the present paper are based upon the interpretation of a series of 197 full-scale static loading (or extraction) tests, of which 172 were carried out by the Laboratoires des Ponts et Chaussées. The tests concerned 96 deep foundations distributed on 48 sites, containing soils made up of such varied materials as clay, silt, sand, gravel or even weathered rock, but also mud, peat, more or less weathered chalk, and marl.

Table I gives an idea of the different types of foundations taken into account. It

Table I

Types of deep foundations	Number of piles	Diameters (cm)	Length of piles (m)
Bored	55	42 to 150	6 to 44
Driven	31	30 to 64	6 to 45
Grouted	8	11 to 70	10 to 31
Barrettes	1	60 x 220	30
Piers	1	200	12

is noted that bored piles are by far the best represented, explained by the present predominance of this type of foundation in France (about 68% of the total). An important point is the fact that almost all the foundations were set up by specialized foundation firms according to usual construction techniques and almost always within the framework of prior tests carried out in order to achieve optimum design of deep foundations for real structures.

As regards bored piles, these included plain bored piles, totally or partially cased piles, mud or fresh-water bored piles using a wide variety of tools (augers, buckets, hammergrabs, bits, valves). Driven (or jacked) piles included H metal or tubular piles with a closed base and reinforced concrete piles. It will however be noted that the barrettes are insufficiently represented and that it has not been possible for the moment to test certain types of piles, such as prestressed tubular piles or metal tubular piles with an open base. Nevertheless, for subsequent proposals, their design method will be commented upon, considering that their behaviour can be likened, without risking too much, to that of foundations whose behaviour we were able to study experimentally.

On almost all the sites investigated by the Laboratoires des Ponts et Chaussées, a total of 39 sites, an endeavour was made, prior to the placement and loading of the piles, to carry out the complete range of soil reconnaissance tests: pressuremeter (Ménard) and static penetrometer tests. When it was possible to take undisturbed samples, an attempt was made to carry out laboratory tests to determine the values of c and ϕ .

A point which should be stressed is the fact that almost all the penetrometer tests were carried out by means of hydraulic static penetrometers of the Paréz type with a diameter of 45 mm, or of the LCPC

electric-point type with a diameter of 36 mm.

Table II gives a good idea of the feasibility and representativeness of the different types of tests for all the sites.

As regards the in-situ tests, table II is very indicative. It shows that:

- whatever the nature of the soil and its compactness, the pressuremeter tests were practically always feasible and utilizable,
- on about 64 % of the sites, the static penetrometer tests (CPT) were not possible.

The nature of many of the soils found in France, because of their complex structure (nodules or boulders, partial cementation) and their high degree of compactness (stiff marl or clay, gravel and weathered rock), explains the difficulties encountered in implementing the static penetrometer (CPT) tests.

3 METHODOLOGY OF APPROACH AND LOADING PROGRAMME

All the piles tested were loaded axially. Where the same pile was subjected to several tests, no account was taken of the results of the first loading, in order to eliminate the effect of the time factor. The shafts of 57 piles (31 sites) were instrumented, notably to establish the amount of the load absorbed by point resistance and skin friction. In most cases, the piles were equipped with removable extensometers [7]. Whenever possible, owing to the effect of the modulus of elasticity E of the pile shaft material on the assessment of forces, this parameter was measured on samples taken directly in the pile shaft. Similarly, every effort was made to define the real geometry of the shaft.

Another important point is the fact that all the tests conducted by the LPC network were carried out according to the guidelines of the LPC Static Test Procedure [8]. It will be noted that, according to this document, the test consists in loading a foundation in increasing steps of equal intensity and duration (60 or 90 minutes) without intermediate unloading (Fig. 1a). As regards the interpretation, it is recommended to plot the characteristic relation $\sigma - Q$ (Fig. 1b) from which is deduced the creep load Q_c [9] [10].

Table II

Type of test undertaken (characteristic parameter)	Total number of sites	Tests actually conducted	Tests considered utilisable or representative afterward	Tests considered partial or unusable (1)	Tests considered not feasible	Possible tests not conducted but offering the certainty of being representative
Ménard pressurometer (p_1)	39	37	34	3	0	2
Static penetrometer (q_c)	39	21	12	9 (refusal)	16 (excessive compactness)	2
Laboratory (c, ϕ)	39	16	7	9 (Excessive scattering)	15	8

(1) The main reason appearing in parentheses.

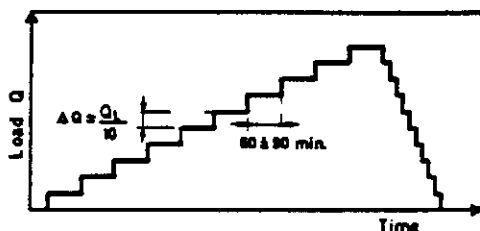

Fig. 1a). Schematic representation of loading programme according to LPC procedure.

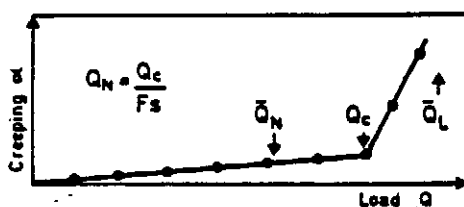

Fig. 1b). Review of graphic construction for determining the creep load Q_c .

4 PRINCIPLES OF PENETROMETER METHOD

Before proposing any readjustment in the design method, the principles involved should be reviewed briefly. These are the principles of the penetrometer method adopted by the FOND 72 document [5] which, it be recalled, is based upon the work of Begemann and Van der Ween [1][2] for point resistance calculation, and Dinesh Mohan [3] for skin friction calculation.

The calculated limit load Q_L of a deep

foundation is the sum of two terms (Fig. 2):

$$Q_L = Q_L^P + Q_L^F \text{ (kN)}$$

where Q_L^P is the limit resistance under the point (kN),

Q_L^F is the limit skin friction on the entire height of the pile shaft (kN).

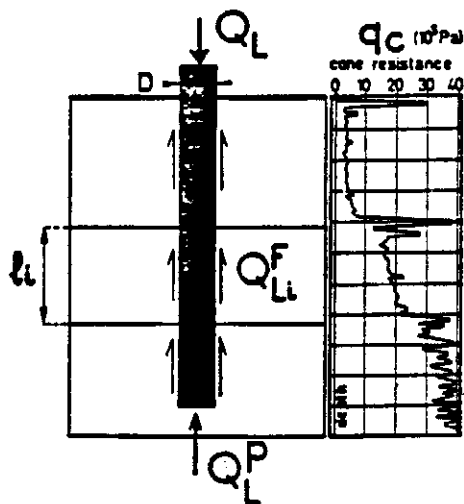

Fig. 2.

In the general case of a multilayer formation in which the distribution of cone resistances q_c as a function of depth is known (Fig. 2), each of these terms will be calculated from the following formula :

$$Q_L^P = q_{ca} \cdot k_c \cdot \frac{\pi D^2}{4} \text{ (kN)}$$

$$Q_L^F = \sum_1^i Q_{Li}^F = \sum_1^i q_{si} \cdot \pi D l_i \text{ (kN)}$$

where successively :

- q_{ca} is the equivalent cone resistance at the level of the pile point (in kN/m^2)
- k_c is the penetrometer bearing capacity factor
- D is the diameter of the foundation (m)
- q_{si} is the limit unit skin friction at the level of the layer i (kN/m^2)
- l_i is the thickness of the layer i (m).

The value of the calculated nominal load Q_N (allowable load) of the pile is obtained by adopting a safety factor of 3 for the point resistance and 2 for the skin friction, so that :

$$Q_N = \frac{Q_L^P}{3} + \frac{Q_L^F}{2} \text{ (kN).}$$

5 CHARACTERISTIC PARAMETERS OF BEARING CAPACITY

As can be seen it is the parameters k_c and q_{ca} which condition the representativeness of the proposed design method. The choice of the mean value q_{ca} also has its importance. The method of obtaining k_c , q_{si} , q_{ca} will thus be defined, with an indication of the conditions and application limits of each of these parameters.

5.1 Equivalent cone resistance q_{ca} (Fig. 3)

This in fact corresponds to an arithmetical mean of the resistances q_c measured along a height between $+a$ over the cone, and $-a$ below the pile point.

In practice, the equivalent cone resistance q_{ca} is calculated in several phases. During a first phase, the curve of the cone resistance q_c is smoothed so as to eliminate the local irregularities of the raw curve. For safety reasons, the smoothed curve is then made to pass closer to the valleys than to the peaks of the raw curve.

During a second phase, beginning with the smoothed curve, we calculate q'_c which is the mean of the smoothed resistance between the values $-a$ and $+a$ where $a = 1,5D$ (Fig. 3).

Finally, the equivalent cone resistance q_{ca} is calculated after clipping the smoothed curve. This peak clipping is carried out so as to eliminate the values higher than $1.3 q'_c$ under the pile point, whereas the values higher than $1.3 q'_c$ and lower than

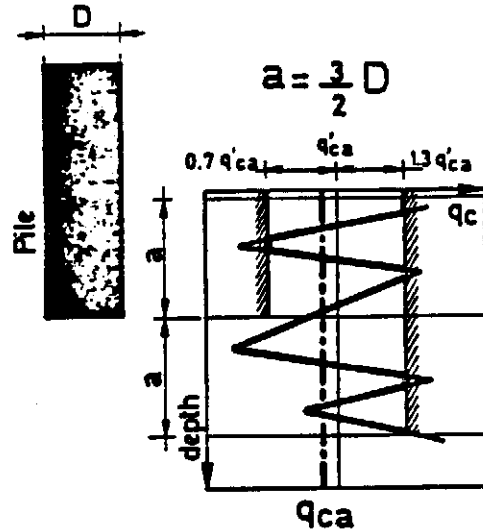

Fig. 3.

$0,7 q'_{ca}$ are eliminated over the pile point (Fig. 3) It goes without saying that all the calculation operations for determining q_{ca} are carried out in practice by computer.

5.2 Penetrometer bearing capacity factor k_c

The different values of this factor, derived from full-scale loading tests, appear in Table III.

Table III. Values of bearing capacity factors k_c for the calculation of the limit point resistance Q_L^P .

Nature of soil	q_c (10^5 Pa)	Factors k_c	
		Group I	Group II
Soft clay and mud	< 10	0,4	0,5
Moderately compact clay	10 to 50	0,35	0,45
Silt and loose sand	< 50	0,40	0,50
Compact to stiff clay and compact silt	> 50	0,45	0,55
Soft chalk	< 50	0,20	0,3
Moderately compact sand and gravel	50 to 120	0,4	0,5
Weathered to fragmented chalk	> 50	0,2	0,4
Compact to very compact sand and gravel	120	0,3	0,4

As can be noted, the values k depend on the nature of the soil and its compactness (q_c) but also, and this is important, on the different pile placement techniques. Each of these techniques is related to one of two groups including respectively [5]:

Group I :

- Plain bored piles
- Mud bored piles
- Type I micropiles (grouted under low pressure)
- Cased bored piles.
- Hollow auger bored piles
- Piers
- Barrettes.

Group II :

- Cast screwed piles
- Driven precast piles
- Prestressed tubular piles
- Driven cast piles
- Jacked metal piles
- Type II micropiles (or small diameter piles grouted under high pressure, with diameters < 250 mm)
- Driven grouted piles (low pressure grouting)
- Driven metal piles
- Driven rammed piles
- Jacked concrete piles
- High pressure grouted piles of large diameter.

As regards driven piles, and in particular driven metal tubular, prestressed piles, or jacked metal piles, the corresponding value of k is applied without reserve to the piles k with a closed base. For H sections and tubular piles with an open base, the values k of Table III will not be entirely adopted unless it can be demonstrated, either with reference to similar cases or, preferably, as a result of a full-scale loading test, that a plug occurs under the pile point, capable of taking up the equivalent of the forces of a point whose section would be determined by the circumscribed perimeter.

It will be noted that the new values of k are on the average twice as low as those presented by the FOND 72 document [5]. In fact, formerly between 1.0 and 0.7, the new values presently vary between 0.2 and 0.55. It is interesting to note that this reduction reflects the fact that the amount of the load taken by the point of a deep foundation is much greater than suggested by usual design methods. It will also be noted that the k values of Table III are given for embedded pile lengths at least equal to the vertical anchoring depth. For all the cases investigated, it was verified that this condition was satisfied.

Figure 4 shows, for some characteristic cases, the level of the measured values of k in relation to the range of values recommended by the FOND 72 document and the authors of this paper.

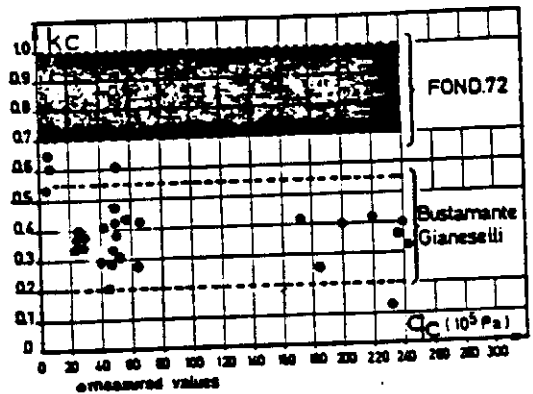

Fig. 4.

5.3 Limit unit skin friction q_{si}

For each layer i , the limit unit skin friction q_{si} is calculated by dividing the cone resistance q_c corresponding to the given level by a coefficient α which makes it possible to allow for the nature of the soil and for the pile production and placement methods :

$$q_{si} = \frac{q_c}{\alpha}$$

The different values of the coefficient α appearing in Table IV constitute average values derived from loading tests. Table IV distinguishes between three main placement categories within which the different types of piles fall :

Category I A :

- Plain bored piles
- Hollow auger bored piles
- Type I micropiles
- Barrettes.
- Mud bored piles
- Cast screwed piles
- Piers

Category I B :

- Cased bored piles (concrete or metal shaft)
- Driven cast piles.

Category II A :

- Driven precast piles
- Jacked concrete piles.
- Prestressed tubular piles

Category II B :

- Driven metal piles
- Jacked metal piles.

Category III A :

- Driven grouted piles
- Driven rammed piles.

Category III B :

- High pressure grouted piles with diameter greater than 250 mm
- Type II micropiles.

Table IV. Values of coefficients α for calculating the limit skin friction Q_L^F .

Nature of soil	q_c (10^5 Pa)	Coefficient α				Maximum value of q_s (10^5 Pa)							
		C a t e g o r y											
		I		II		III		IV		V			
		I A	I B	II A	II B	I A	I B	II A	II B	III A	III B		
Soft clay and mud	<10	30	30	30	30	0,15	0,15	0,15	0,15	0,35	-		
Moderately compact clay	10 to 50	40	80	40	80	(0,8) 0,35	(0,8) 0,35	(0,8) 0,35	0,35	0,8	≥1,20		
Silt and loose sand	<50	60	150	60	120	0,35	0,35	0,35	0,35	0,8	-		
Compact to stiff clay and compact silt	>50	60	120	60	120	(0,8) 0,35	(0,8) 0,35	(0,8) 0,35	0,35	0,8	≥2,0		
Soft chalk	<50	100	120	100	120	0,35	0,35	0,35	0,35	0,8	-		
Moderately compact sand and gravel	50 to 120	100	200	100	200	(1,2) 0,8	(0,8) 0,35	(1,2) 0,8	0,8	1,20	≥2,0		
Weathered to fragmented chalk	>50	60	80	60	80	(1,5) 1,2	(1,2) 0,8	(1,5) 1,2	1,20	1,5	≥2,0		
Compact to very compact sand and gravel	>120	150	300	150	200	(1,5) 1,2	(1,2) 0,8	(1,5) 1,20	1,20	1,5	≥2,0		

It will be noted that categories IIIA and IIIB appear directly under the heading of the maximum values of the limit unit skin friction q_s not to be exceeded. These maximum values, moreover given for all types of piles, are required (with the reception of grouted piles) owing to the scattering which can result from the taking into account of cone resistances q_c which are not highly representative (peaks corresponding to the presence of localized hard elements, non-compliance with standard penetration rates, poor condition of cones, excess pore pressure, deviation of push-rods, etc.) [12] [13].

It will finally be noted that, as concerns the maximum values of q_s proposed in Table IV, in certain cases two values are given. The first corresponds to placement offering very little dependability as concerns execution quality; on the other hand, the second - appearing in parentheses - corresponds to very careful execution and to the choice of a technology involving minimum disturbance of the soil in contact with the pile shaft and capable of yielding optimum friction values. Thus, for major projects in which a large number of piles is planned, it is highly recommended to check experimentally, by one or more prior full-scale loading tests, whether it is possible to adopt the maximum friction values q_s indicated in Table IV. In many cases, the adoption of the maximum values will lead to gains which will compensate amply for the expenditures entailed by such tests.

In general, with regard to the application of the values of Table IV, it is not necessary to make allowances for the diameter of the pile or more precisely for the radius of curvature of the foundation.

It will be noted that the values in Table III and IV are in general of the same order as those proposed by Philipponnat [14].

6 CONSEQUENCES OF THE READJUSTMENT OF PENETROMETER RULES

To determine the effect of the readjustment of the characteristic parameters k and α on bearing capacity, and in particular on the nominal bearing capacity Q_N , their values, calculated according to the recommendations of the FOND 72 document and Tables III and IV, were compared with the experimental values Q_N (allowable load) deduced from the critical creeping load Q_C^* .

The comparison was made only for the results relative to piles loaded up to the limit load Q_L and, when the same pile had undergone several consecutive loadings, for the first loading only.

The histogram relative to the nominal bearing capacities (Fig. 5) shows a tightening of the extreme values and, significantly, a reduction in the overstated bearing capacities. It will be noted that the new parameters taken into account, despite a

* It will be recalled that Q_N is obtained by applying to the creep load Q_C a reduction safety factor equal to 1.4.

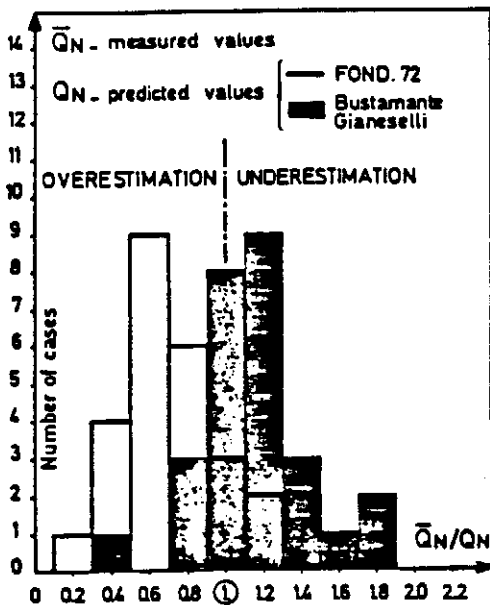

Fig. 5.

substantial reduction in the bearing capacity factors k_c , do not lead to the consistent overdimensioning of the piles or, in other words, to an increase in their embedded lengths for the same bearing capacities. It will also be noted that the new parameters make it possible to reduce very clearly the overdimensioning. Fig. 6 shows the effect of the readjustment of the factor k_c on the point resistances Q_c^P . Finally, it will be noted that on the whole, the adoption of new values for k_c and α leads to the location of the predicted loads of a pile closer to the real case than allowed by the rules proposed by the FOND 72 document.

7 CONCLUSIONS

A large number of full-scale loading tests, with point resistance and skin friction measurements, have provided experimental data making it possible to propose a method for predicting the bearing capacity of deep foundations based upon the use of the cone resistance q_c measured with the static penetrometer CPT^c.

It has however been observed :

- that the predominance of compact or complex-structured soils in France made it impossible, in over half the cases, to use the CPT penetrometer and, consequently, to apply the associated design method ;
- that, in the case where a penetrometer CPT

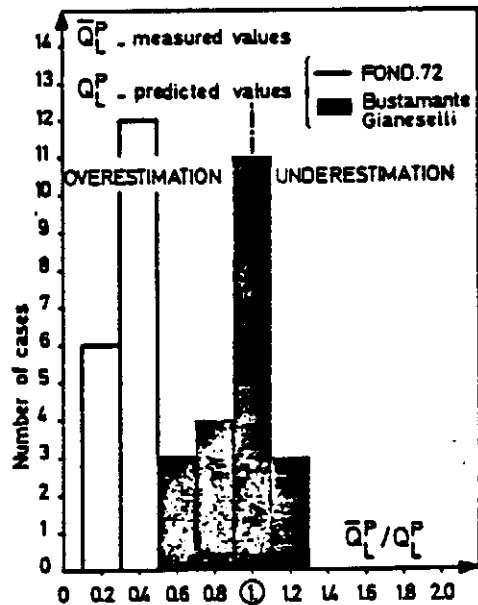

Fig. 6.

profile was available, the associated prediction method generally appeared to be less reliable than the design method based upon the pressuremeter test.

Finally, the absence or the limited number of data relative to certain foundations suggests that the proposed design method can be improved but than only the multiplication of full-scale loading tests carried out on properly instrumented deep foundations using a standard procedure will enable more reliable experimentation.

8 BIBLIOGRAPHICAL REFERENCES

- [1] Begemann, H.K., The use of the static soil penetrometer in Holland. New Zealand Engineering, Fev. 1963.
- [2] Van Der Ween, Préviation de la capacité portante d'un pieu à partir de l'essai de pénétration statique. 4^e C.I.M.S. Vol. II, 1957.
- [3] Dinesh Mohan, Virendra Kumar, Load bearing capacity of piles. Geotechnique Inter. J. Soil Mech. Vol. 13, 1, Mars 1963, p.76-86.
- [4] Ménard L., Calcul de la force portante des fondations sur la base des résultats des essais pressiométriques. Soils-Soils, 5, Juin 1963, p. 9-28.

- [5] FOND. 72. Fondations courantes d'ouvrages d'art. LCPC-SETRA, Fév. 1972.
- [6] Bustamante M. & Gianceselli L., Prévission de la capacité portante des pieux isolés sous charge verticale. Bulletin Liaison Labo. P. et Ch., n° 113, Mai-Juin 1981.
- [7] Jézéquel J.F. & Bustamante M., Mesure des élongations dans les pieux et tirants à l'aide d'extensomètres amovibles. Travaux n° 489, Déc. 1975.
- [8] Projet de Mode Opératoire de l'Essai Statique de Fondations Profondes. LCPC, Mai 1972.
- [9] Bustamante M. & Gianceselli L., Capacité portante des pieux isolés sous charge statique. Rapport de recherche interne, LCPC, Déc. 1978-1979.
- [10] Cambefort H. & Chadeisson R., Critère pour l'évaluation de la force portante d'un pieu. Proc. 5th Int. Conf. Sol Mech. Found. Eng., 1961.
- [11] CSTB - Travaux de fondations profondes pour le bâtiment. Document Technique Unifié n° 132, Juin 1978.
- [12] Jézéquel J.F., Les pénétromètres statiques. Bulletin de Liaison Labo. P. et Ch. n° 36, Janv. 1969. Influence du mode d'emploi sur la résistance de pointe.
- [13] Amar S., Baguelin F., Jézéquel J.F. & Nazeret J.P., Utilisation du pénétromètre statique dans les Laboratoires des Ponts et Chaussées. Annales de l'ITBTP, n° 340, Juin 1976.
- [14] Philipponnat G., Méthode pratique de calcul d'un pieu isolé à l'aide du pénétromètre statique. Revue Française de Géotechnique n° 10.